

KHM 190 YS

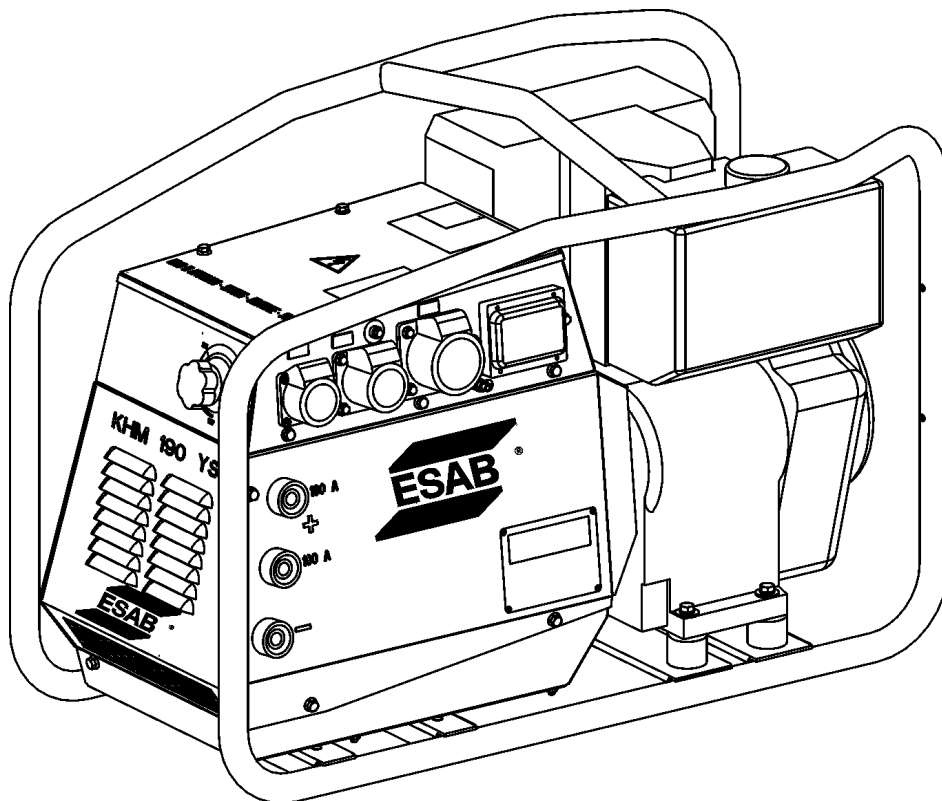

Instruction manual
Bedienungs- und Wartungsanleitung
Emploi et entyretien
Gebruiks- en onderhoudshandleiding



DECLARATION OF CONFORMITY

ESAB Welding Equipment AB, S--695 81 Laxå, Sweden, gives its unreserved guarantee that the engine driven welder KHM 190 YS with the code number 0794000882/3 complies with the Community Directives and related modifications 98/37/CE - 73/23/CE - 89/336/CE and, in order to check the conformity, the following harmonized standards EN 292-1 - EN 292-2 - EN 60974-1 - EN 60204-1 - EN 50199 and other standards or directives like 84/535/CE - ISO 8528 have been consulted .

Laxå 2001

A handwritten signature in black ink, appearing to read "Joakim Cahlin". The signature is fluid and cursive, written over a thin horizontal line.

Joakim Cahlin
ESAB Welding Equipment AB
695 81 LAXÅ
SWEDEN

Tel. + 46 58 481000

fax +46 584 411924

Dear Customer,

We wish to thank you for having bought this product.

Please take time to read this manual and familiarize yourself with the machine before attempting to use it.

If you should have questions or problems please contact the nearest authorized Service Center. They have the experience and original spare parts. The use of non-original spare parts will void the warranty.

TABLE OF CONTENTS

<u>DESCRIPTION</u>	<u>PAGE</u>
<u>GENERAL INFORMATION</u>	
INFORMATION ABOUT THIS MANUAL	M 2
DESCRIPTION - SYMBOLS	M 2.1
PRECAUTIONS - GENERAL	M 2.5
PRECAUTIONS - ENGINE DRIVEN WELDERS	M 2.5.1
TRANSPORT	M 4.1
ASSEMBLY OF TROLLEY	M 6
INSTALLATION INFORMATION	M 2.6, M 2.7
<u>OPERATION</u>	
UNPACKING	M 3
PREPARING THE UNIT	M 20.1
STARTING THE ENGINE	M 21
STOPPING THE ENGINE	M 22
CONTROLS	M 31
USE AS A WELDER	M 34
USE AS A GENERATOR	M 37
ENGINE PROTECTION	M 39.6
MAINTENANCE	M 43, M 43.2
STORAGE	M 45
TECHNICAL DATA AND MACHINE DESCRIPTION	M 51, 51.1
<u>SCHEMATICS AND SPARE PARTS</u>	
ORDERING SPARE PARTS	R 1,
WIRING DIAGRAM - AUXILIARY	M 61.1
WIRING DIAGRAM – WELDING POWER	M 61.2
WIRING DIAGRAM – ENGINE	M 61.3
WIRING DIAGRAM - AUXILIARY	M 61.4
WIRING DIAGRAM – WELDING POWER	M 61.5
DESCRIPTION - ELECTRICAL SYSTEM	M 60
SPARE PARTS	DR 3, DR 3.1,
SPARE PARTS	DR 5, DR 5.1
SPARE PARTS	DR 7, DR 7.1
KIT DECAL	
TROLLEY	KA 4

GENERAL INFORMATION

- In the envelope where you found this manual you will also find an Owner's manual for the engine, and accessories (if required).

This product has been designed for welding and generation of electrical power for tools and other electrical devices used in construction; ANY OTHER USE, is not permitted and we cannot be held responsible for injuries or damages resulting from such incorrect use.

Our products are made in conformity with the safety norms in force in order to avoid injury to persons or damage to the machine or other things.

Warranty is not valid if not carried out by ESAB authorized service agent.

Making modifications to the machine without our written authorization will void the warranty and release us from any liability.

ABOUT THIS MANUAL

Before using the machine please read this manual attentively and follow the instructions contained in it. This will help avoid problems, possible injury and damage to the machine.

The manual is written for experienced, qualified personnel, who are familiar with health and safety laws and related regulations.

This manual is an integral part of the product and should be kept in a safe place so that it will be available for consultation during the life of the product. If the machine is sold the manual should be transferred to the new owner.

Some figures contained in this manual are designed to help identify certain parts and may not correspond to the machine in your possession.

Notice: *the manufacturer may make improvements or modifications to the product or its accessories as described in this manual without updating the manual.*

HEADINGS USED IN THIS MANUAL

The headings used in this manual are designed to call your attention to potential hazards and important aspects of the operation of the machine...

**DANGEROUS**

Indicates a strong possibility of severe personal injury or death if instructions are not followed.

**WARNING**

Indicates a possibility of personal injury or equipment damage if instructions are not followed

**CAUTION**

Indicates that equipment or property damage can result if instructions are not followed.

**IMPORTANT****NOTE****ATTENTION**

These headings give helpful information about the preparation, operation and care of the machine.



GENERAL SYMBOLS



STOP – Read with great attention



Read with attention



WRENCH - Use the correct tools for the type of work being done

WARNING SYMBOLS



ATTENTION - If this advice is not followed people or things can be hurt or damaged.



HIGH VOLTAGE - Do not touch – risk of injury or death.



FIRE - Risk of fire.



HEAT - Hot surfaces.



EXPLOSIVE - Explosive material or danger of explosion, in general.



NO WATER - Do not use water as it can cause shortcircuits or other damage.



NO SMOKING - Cigarettes, matches or lighters can start a fire or explosion.



ACIDS - Danger of corrosion or burns.

SAFETY SYMBOLS

Use the correct protective devices for the type of welding being done



Use protective clothing, etc. specifically designed for the type of welding being done.

Protect yourself when doing maintenance on the machine -



It is advisable to protect yourself when carrying out maintenance, such as filling the battery, refuelling, etc.

Pay attention to safety precautions when moving the machine



Refer to the instructions before moving the machine

Wear indicated safety clothing -



It is compulsory to wear the personal protection items shown when using the equipment.

Use required safety devices -



Safety devices suitable for the type of welding and the location of the job must be used.

Do not use water on electrical fires -



It is prohibited to use water to put out fires in electrical equipment.

Do not touch without having disconnected the electricity -



It is prohibited to work on the machine until the electricity has been turned off.

Welding prohibited -



It is forbidden to weld in areas containing explosive gases.

⚠ IMPORTANT

- ☞ Read and understand these instructions.
- ☞ Before installing, operating or servicing this equipment, read the operating manuals of the welder and of the engine.
- ☞ Not observing the information in the manuals can result in personal injury and/or damage to the equipment and other property.
- ☞ Respect all safety regulations and laws when operating this equipment.

⚠ WARNING

Do not remove or disable protective devices

Removing or disabling protective devices on the machine is prohibited.

Do not use the machine if it is not in good technical condition

The machine must be in good working order before being used. Defects, especially those which regard the safety of the machine, must be repaired before using the machine.

ENGINE FUELLING

- ⇒ Stop engine when fuelling.
- ⇒ Do not smoke, avoid open flames and sparks, and do not use electric tools when fuelling.
- ⇒ Unscrew the fuel cap slowly to let out the fuel vapours.
- ⇒ Do not over-fill the tank.
- ⇒ Avoid spilling fuel on hot engine.
- ⇒ Wipe up spilled fuel before starting engine.
- ⇒ Shut off fuel cock, if present, or remove fuel from tank before moving machine

FOR BATTERY EQUIPPED UNITS ONLY

- ⇒ Sparks may cause the explosion of battery vapours

WATER COOLED ENGINES ONLY

- ⇒ Slowly unscrew the cooling liquid cap of a hot engine to allow vapours to escape.
- ⇒ Hot vapor and heated cooling liquid under pressure can burn face, eyes, skin.



☞ **FIRST AID.** In case the operator should be sprayed by accident, from corrosive liquids a/o hot toxic gas or whatever event which may cause serious injuries or death, predispose the first aid in accordance with the ruling labour accident standards or of local instructions.

Skin contact	Wash with water and soap
Eyes contact	Irrigate with plenty of water, if the irritation persists contact a specialist
Ingestion	Do not induce vomit as to avoid the intake of vomit into the lungs, send for a doctor
Suction of liquids from lungs	If you suppose that vomit has entered the lungs (as in case of spontaneous vomit) take the subject to the hospital with the utmost urgency
Inhalation	In case of exposure to high concentration of vapours take immediately to a non polluted zone the person involved



☞ **FIRE PREVENTION.** In case the working zone, for whatsoever cause goes on fire with flames liable to cause severe wounds or death, follow the first aid as described by the ruling norms or local ones.

EXTINCTION MEANS

Appropriated	Carbonate anhydride (or carbon dioxide) powder, foam, nebulized water
Not to be used	Avoid the use of water jets
Other indications	Cover eventual shedding not on fire with foam or sand, use water jets to cool off the surfaces close to the fire
Particular protection	Wear an autorespiratory mask when heavy smoke is present
Useful warnings	Avoid, by appropriate means to have oil sprays over metallic hot surfaces or over electric contacts (switches, plugs, etc.). In case of oil sprinkling from pressure circuits, keep in mind that the inflammability point is very low.

⚠ WARNING

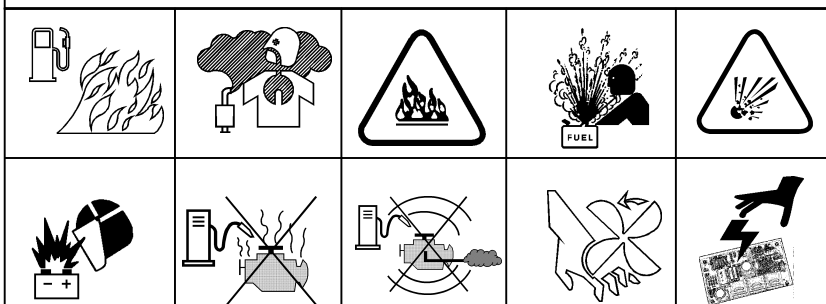

⚠ CAUTION

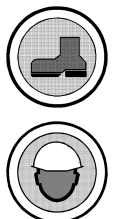
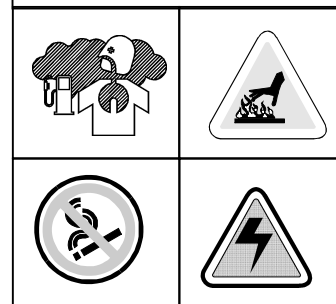

WARNING

THE MACHINE MUST NOT BE USED IN AREAS WITH EXPLOSIVE ATMOSPHERE

PRECAUTIONS

The operator of the welder is responsible for the security of the people who work with the welder and for those in the vicinity.

The security measures must satisfy the rules and regulations for engine driven welders.

The information given below is in addition to the local security norms.

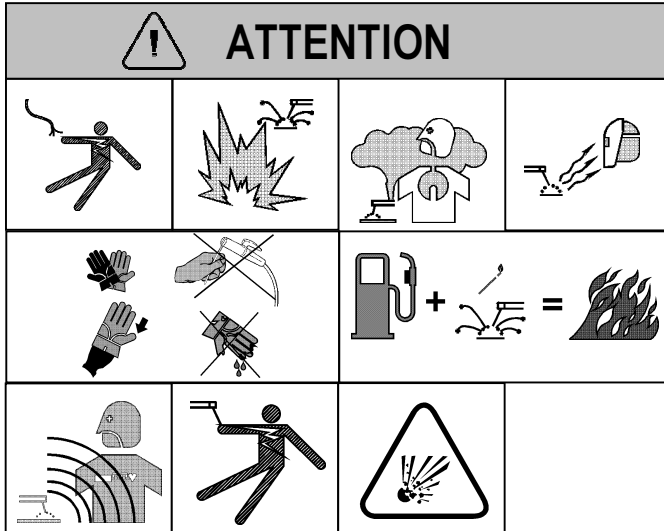

⇒ Make sure that the area is safe before starting any welding operation.

⇒ Do not touch any bare wires, leads or contacts as they may be live and there is danger of electric shock which can cause death or serious burns. The electrode and welding cables, etc. are live when the unit is operating.

⇒ Do not touch any electrical parts or the electrode while standing in water or with wet hands, feet or clothes.

⇒ Insulate yourself from the work surface while welding. Use carpets or other insulating materials to avoid physical contact with the work surface and the floor.

⇒ Always wear dry, insulating gloves, without holes, and body protection.

⇒ Do not wind cables around the body.

⇒ Use ear protections if the noise level is high.

⇒ Keep flammable material away from the welding area.

⇒ Do not weld on containers which contain flammable material.

⇒ Do not weld near refuelling areas.

⇒ Do not weld on easily flammable surfaces.

⇒ Do not use the welder to defrost (thaw) pipes.

⇒ Remove the electrode from the electrode holder, when not welding.

⇒ Avoid inhaling fumes by providing a ventilation system or, if not possible, use an approved air breather.

⇒ Do not work in closed areas where there is no fresh air flow.

⇒ Protect face and eyes (protective mask with suitable dark lens and side screens), ears and body (non-flammable protective clothes).

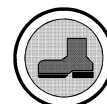



NOTE

In case you have to move or transport the machine, follow the instructions as shown in the figures.

Ship the machine **without** petrol in the tank, **without** oil in the engine and **without** electrolyte in the battery. Be sure that the transportation devices are adequate for the size and weight of the machine.

DO NOT TRANSPORT ACCESSORIES OR OTHER ITEMS WHICH COULD INCREASE THE WEIGHT AND/OR CHANGE THE CENTER OF GRAVITY OF THE MACHINE.

DO NOT DRAG THE MACHINE OR TOW IT ON PUBLIC ROADS UNLESS IT IS MOUNTED ON A HOMOLOGATED TRAILER.

Not following these instructions could cause injury or damage to the machine.

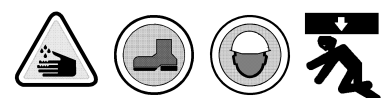
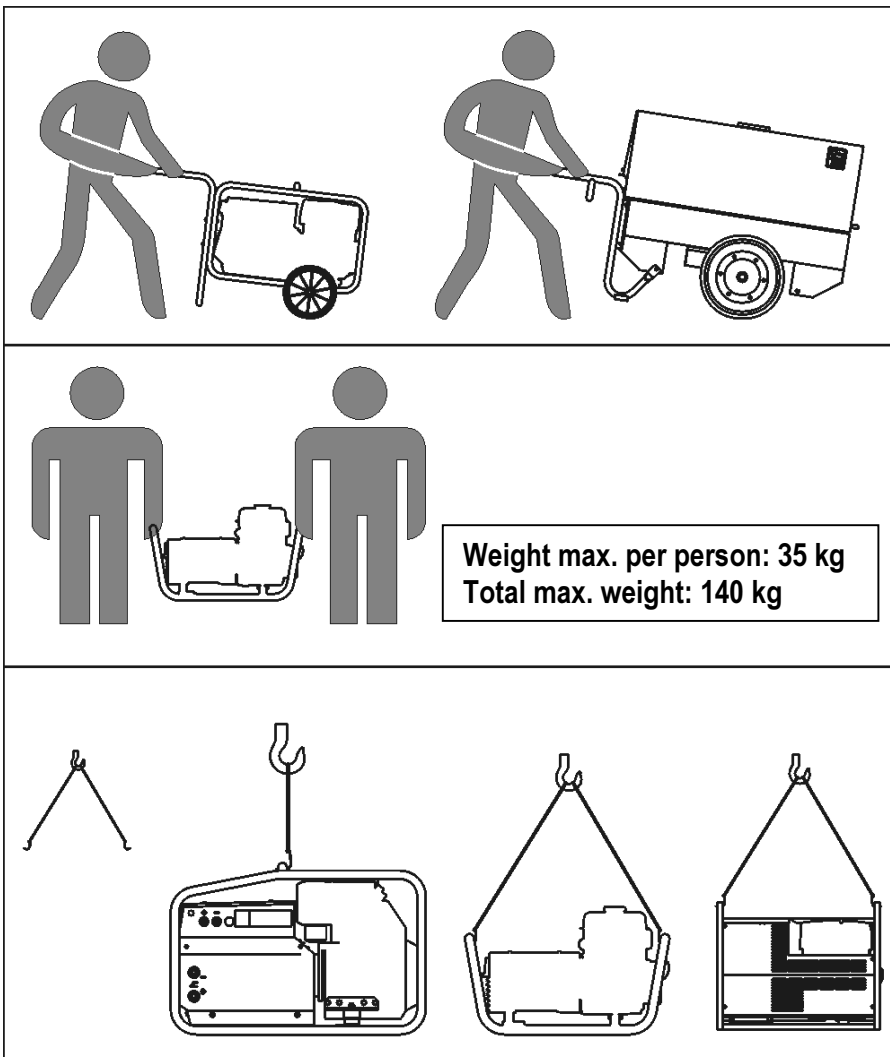

Note: For assembling the generating set on the trolley please keep to following instructions:

1) - Lift the generating set (by means of suitable hook).

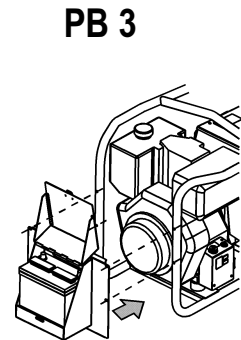
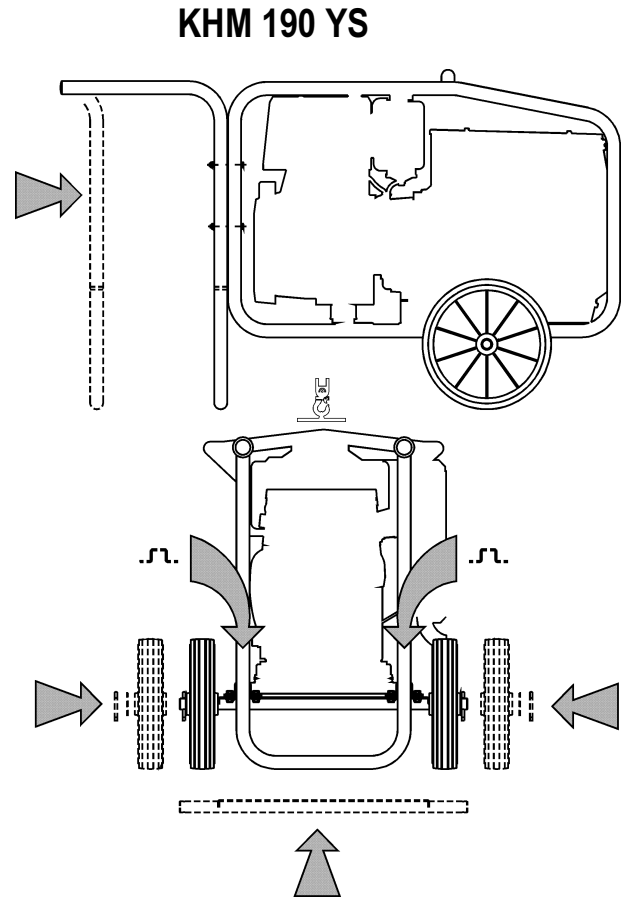
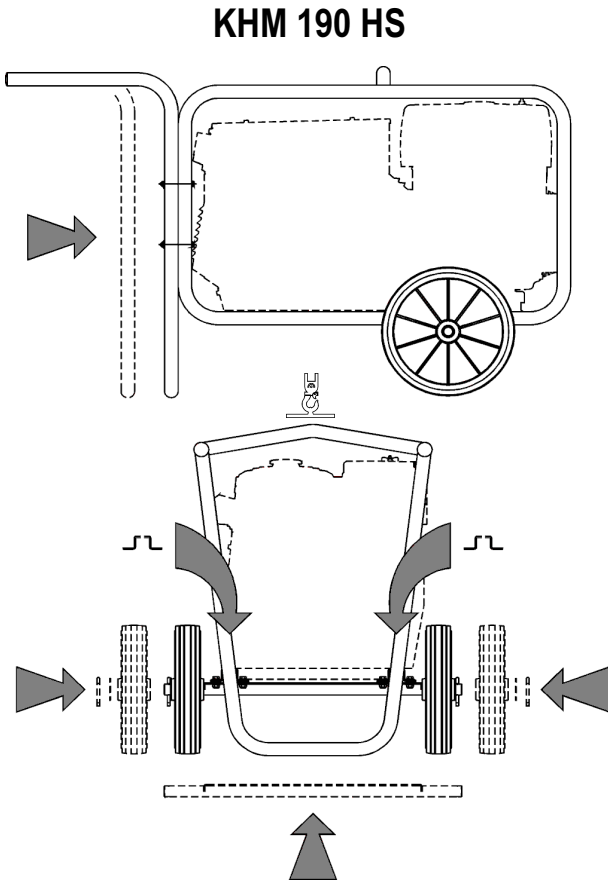

⚠ ATTENTION

Do not substitute the original tires with other types

⚠ ATTENTION
The accessory cannot be removed from the machine and used separately (actioned manually) for the transport of loads or anyway for used different from the machine movements.

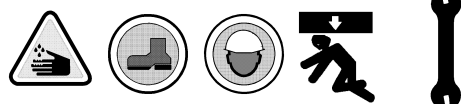

INSTALLATION INFORMATION

DIESEL ENGINES

- Use in open space with fresh air flow or vent exhaust gases far from the work area.

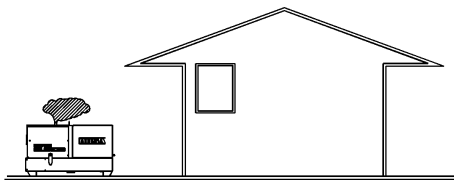
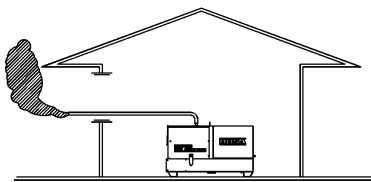
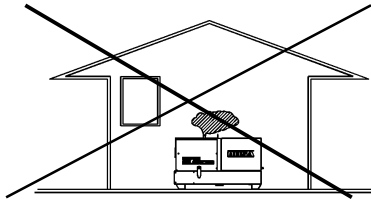

☞ Assure that the hot air and/or exhaust gas from the machine are vented and are not recirculated in the machine. Hot air and/or exhaust gas which is recirculated will cause overheating of the machine and poor combustion in the engine

☞ Make sure that the machine does not move during operation.



Protect the machine from rain and do not put it in a location where there is danger of flooding.

Water infiltration can cause short circuits, which can be dangerous for persons and can damage the machine.

The degree of protection, of the machine is written the rating plate and in this manual at the "Technical Data" page.

MOVING THE MACHINE

Before moving the machine turn off the engine and disconnect all cables, which could impede the move.

POSITIONING THE MACHINE

Place the machine on a level surface at a distance of at least 1,5 m from buildings or other structures.

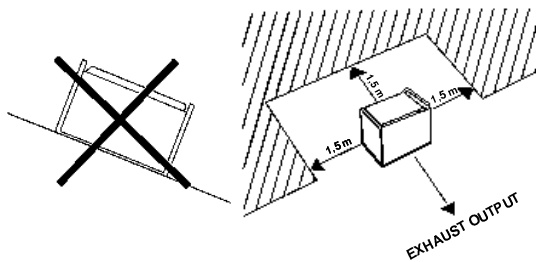

If the surface is not level be sure that the angle of the machine does not exceed the values shown in the drawings below.

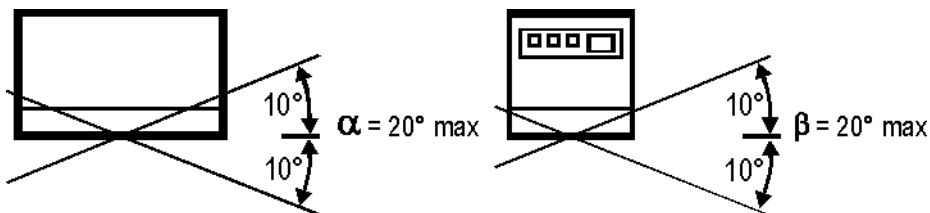

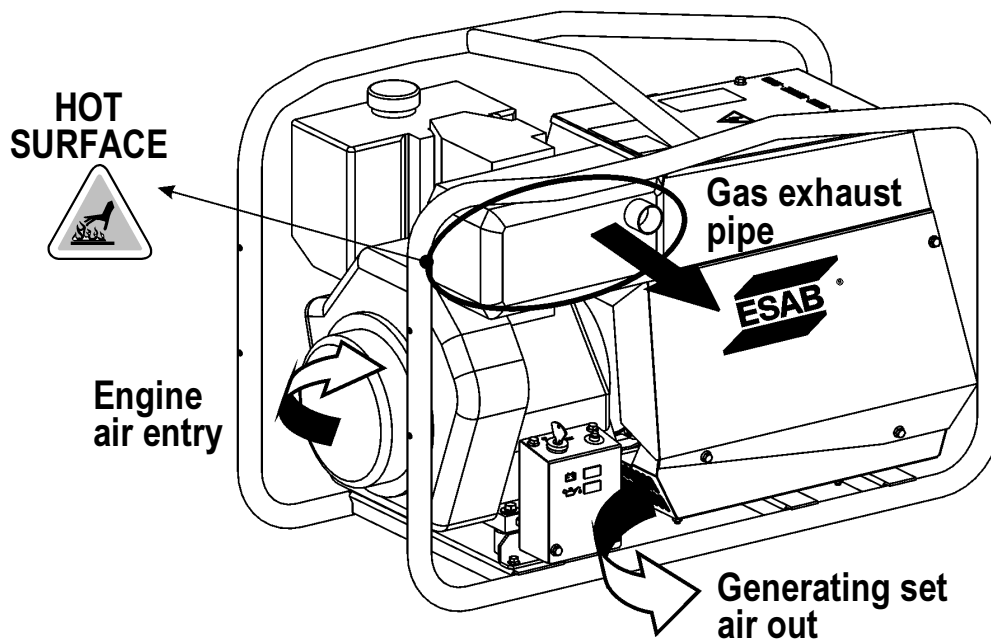
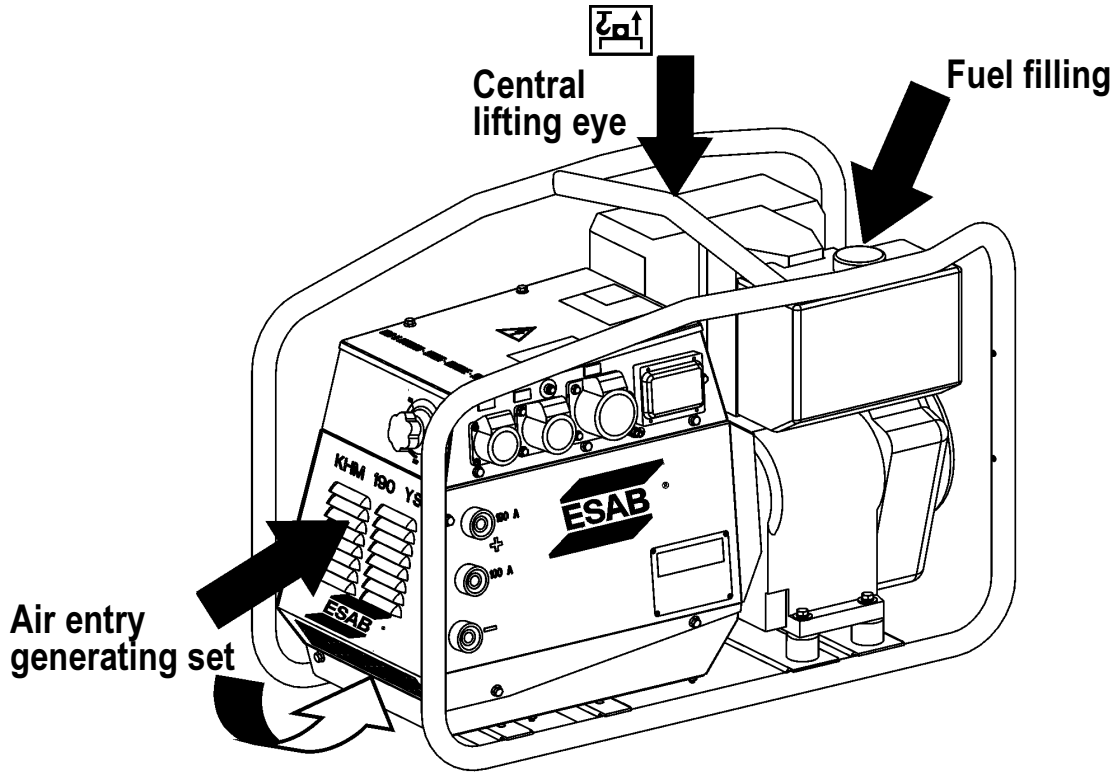

▲ GENERAL PACKING INFORMATION

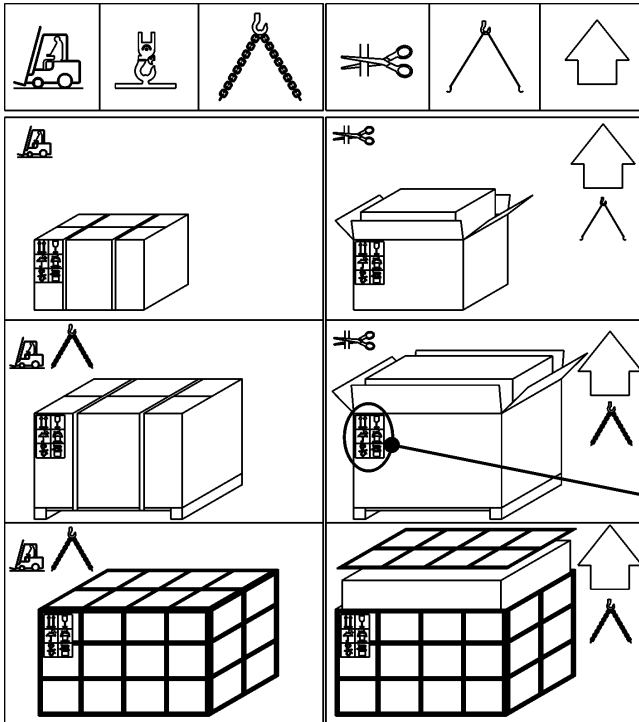

Upon receipt of the goods make sure that the product has not been damaged during transport. In case of damage or missing items you must inform your freight forwarder immediately.



Packing materials must be disposed of according to local regulations.

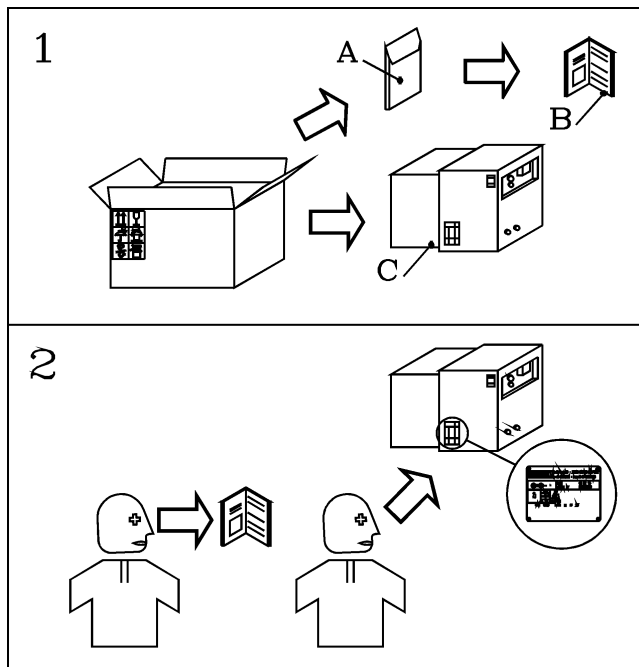
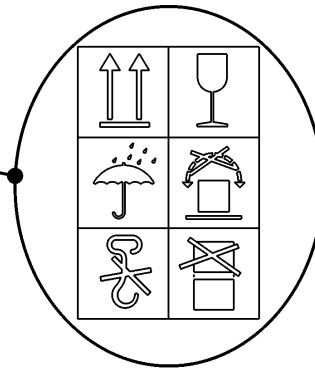

UNPACKING THE MACHINE

- 1) Take the machine (C) out of the carton. Locate the User's Manual (B), which is packed together with the engine manual and accessories in a plastic envelope (A). This envelope may be under or inside the machine.
- 2) Check the rating plate on the machine and confirm that the serial number and model are the same as shown on the packing note/invoice.

NB.: For further information on preparing the unit for use refer to the related parts of this manual.



BATTERY

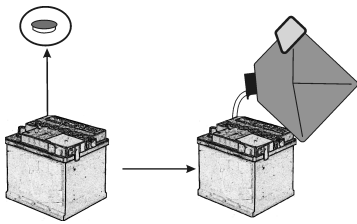

Take the battery out of the machine.

Fill the battery to the maximum level with electrolyte. Wait for about 30 minutes and top up with electrolyte.

In case of spilled acid, rinse with water before putting the battery back into the machine and reconnecting cables.

FUEL

Fill the tank with good quality diesel fuel.

ATTENTION: Diesel fuel is highly inflammable; before filling the tank, stop the engine. Do not fuel in the presence of open flames.



If fuel is spilled on the engine, clean it immediately before starting up the engine.

WARNING



Sulfuric acid is corrosive. Protect hands, eyes and *clothes*, ... Take the battery out of the machine for filling. Warranty **VOIDED** for damages due to spilled acid.

GROUND CONNECTION

A good ground is obligatory for all models with GFI (ground fault interrupter). This protective device will not protect the operator unless there is a good ground.

Use a good quality ground cable and connect it to the grounding point of the machine. Follow all local rules and/or regulations in force.

Machines with Isometer protection do not need to be grounded.

Once the above operations have been completed, the machine can be used.

LUBRICANT

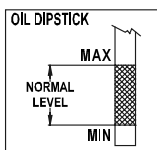

Check the level of the engine oil using the oil dipstick. The level should be between the minimum and maximum marks. If necessary, add more oil.

If the air filter is of the oil bath type, fill it with the same oil up to the level indicated on the filter.

RECOMMENDED SAE VISCOSITY GRADES

For the type and viscosity of oil refer to owner's manual for the engine (supplied with the machine).

NOTE: Before starting the engine read the instructions in the owner's manual for the engine.

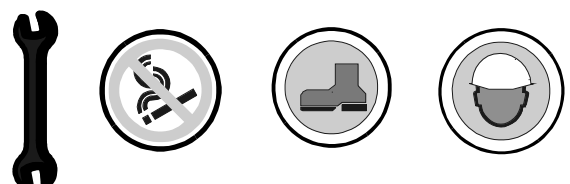

Check daily

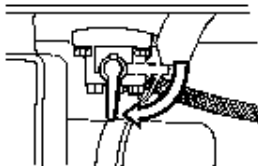
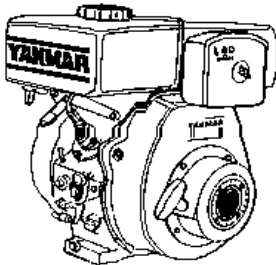

Open fuel cock



Accelerator lever must be in the "START" position.

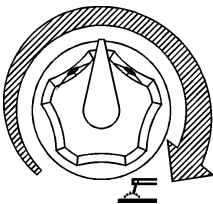

For welders with manual current control, turn the current adjusting knob to the maximum position (fully clockwise).

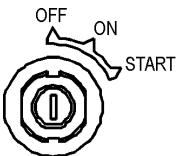

.Turn the starter key to the "START" position. Once the engine has started let the key return to the "ON" position.

EMERGENCY RECOIL START



Grasp the starter handle as shown.



Pull the starter rope until you feel resistance...

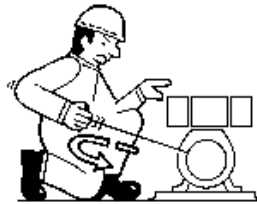

and let it return to its original position

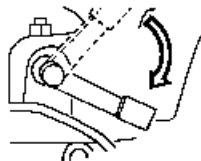

press the decompression lever on the cylinder cover down...



and pull the rope firmly as far as it will go. If necessary use two hands.

NOTE

If battery is not connected, disconnect voltage regulator to prevent damage.

IMPORTANT

RUNNING IN

During the first 50 hours do not use the unit at more than 60% of full load. Check the oil level regularly..

☞ Before stopping the engine **it is compulsory** to:

- disconnect or shut off any loads which are connected to the unit auxiliary outputs.

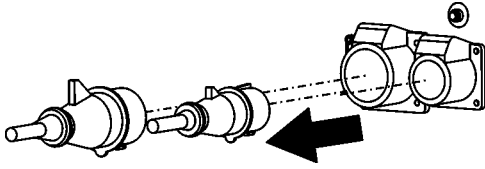

- stop welding.

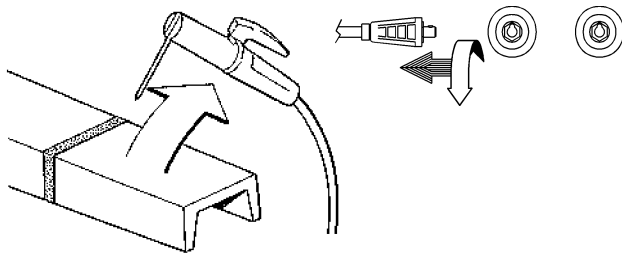

To stop the engine:

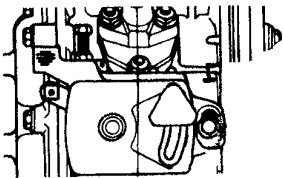

Move the engine speed lever to the "STOP" position.

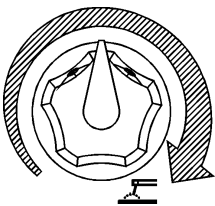

For welders with manual current control, turn the welding current control knob to minimum position (fully counter-clockwise)

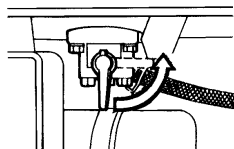

Turn off the fuel cock

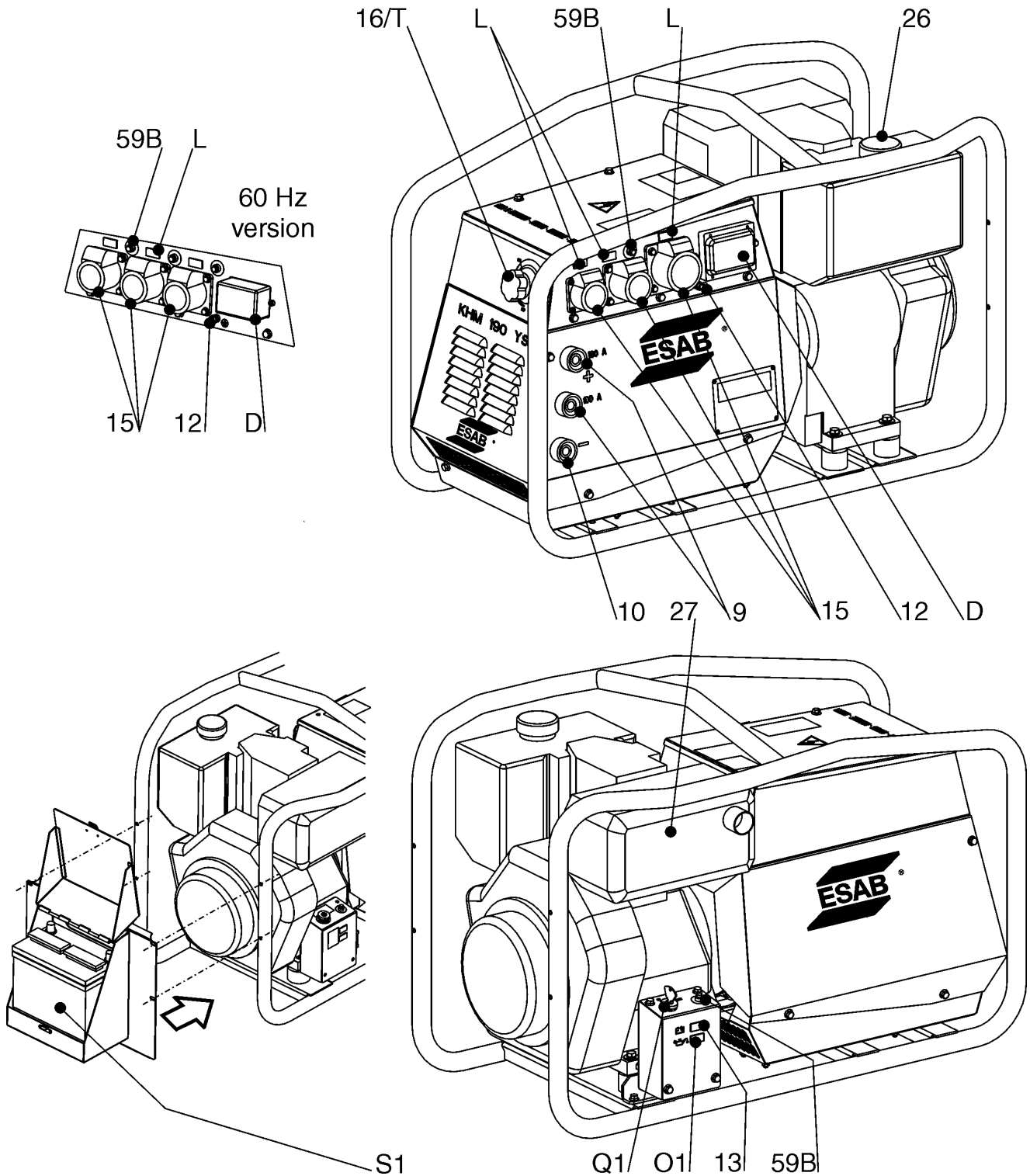

DESCRIPTION	9	Welding socket (+)	59A	Engine circuit breaker
	10	Welding socket (-)	59B	Aux current circuit breaker
	12	Earth terminal	D	Ground fault interrupter (30 mA)
	13	Battery charge warning light	L	A.C. output indicator
	15	A.C. socket	O1	Oil pressure warning light
	16	Accelerator lever	Q1	Starter key
	22	Engine air filter	S1	Battery
	27	Muffler	T	Welding current regulator



ATTENTION

When the machine is running the auxiliary power sockets and the welding sockets are live.



ATTENTION

Be sure that the machine is grounded before using it. Without a ground the GFI (ground fault interrupter) will not function.

CONNECT WELDING CABLES

For direct current electrode positive, connect work cable to negative (-) terminal and electrode holder to positive (+) terminal. For direct current electrode negative, reverse cable connections. Turn them clockwise to lock them in position. Loose plugs will result in poor welding and damage to both plug and socket.

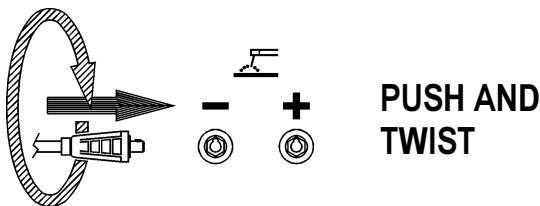

☞ Make sure that the ground clamp makes a good connection and is near the welding position.

WELDING CURRENT REGULATION

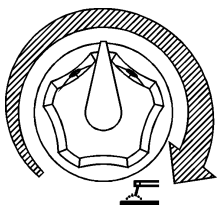

Once the welding current range has been chosen by attaching the electrode holder lead to the corresponding socket, the welding current is adjusted by turning the knob on the front panel. The knob regulates the rpm of the engine.



ATTENTION

To reduce the risk of electromagnetic interference, keep the welding cable length short and keep them on or near the ground. Ensure that the machine is grounded. If possible, welding operations should not be done near sensitive electronic devices.



WARNING

When the machine is running the auxiliary power sockets and the welding sockets are live.



CAUTION

The auxiliary output should never be connected to the mains or to any other source of electric power

ENGINE SPEED FOR CORRECT VOLTAGE AND FREQUENCY

Turn the welding current regulating knob fully clockwise to put the engine at its maximum rpm. If the engine is not at full rpm the voltage and the frequency of the auxiliary power will not be correct. At no load the voltage can be 10% above nominal and at full load the voltage can be 10% below nominal.

PLUGS AND CABLES

Before connecting a load to the socket check that the cables are in good condition and that the plug is wired correctly.

POWER ON LIGHT

The light (L), located above each socket, lights up when there is power available from the socket.

If the warning light does not light, check that the engine is at maximum rpm, that the GFI (ground fault interrupter) is inserted and that the circuit breaker is functioning.

When drawing power from more than one socket at the same time, the power available is that indicated for each socket but the total cannot exceed the maximum shown on the rating plate.

GROUND FAULT INTERRUPTER CIRCUIT BREAKER - GFI (also called EARTH LEAKAGE CIRCUIT BREAKER - ELCB)

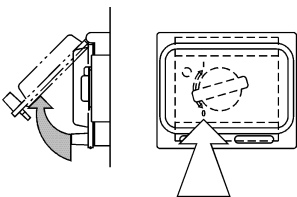

Turn on the GFI (ground fault interrupter) (D) by pushing the lever upwards.

The GFI (ground fault interrupter) is a safety device, which protects the operator in the event of a malfunction. The GFI (ground fault interrupter) shuts off the power to the three

and single-phase sockets there is a leakage current of more than 30mA.



WARNING

Be sure that the machine is grounded before using it. Without a ground the GFI (ground fault interrupter) will not function.

CIRCUIT BREAKERS FOR SOCKETS

If you overload the socket the circuit breaker will automatically switch off the power.

To reset the circuit breaker, disconnect the load, wait a few seconds for the circuit breaker to cool down and then push the button. The button should stay depressed. If the circuit breaker button does not stay in, let it cool down and try again. If it still will not stay in call the service.

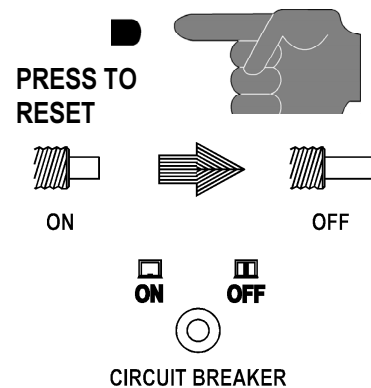

Before reconnecting the load check that the power required is within the rating of the socket. A load which is too large for the socket will cause the circuit breaker to intervene. If, after reconnecting the load, the circuit breaker opens again, check the connections, wires, etc. of the load to find the fault.



The engine protection, in case of low oil pressure, is shown by the warning light without the engine stopping.



The same as for as the battery charger warning light in concerned, the anomaly is shown without the engine stopping.



The engine thermic protection clicks for super-current of the battery charger.

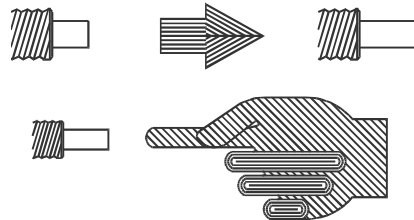

The thermic protection is re-established pressing the central pole.

These devices come in function turning the starting key of the engine.

If the thermic protection should continue to intervene, check:

- the battery charger and its connections
- the charge condition of the battery.

If the trouble should persist, please turn to your Assistance Centre.

Once the cause of the problem is removed, to assure the protection it is enough to put the starting key to zero ("OFF" position) and start the engine again.

WARNING		
	<ul style="list-style-type: none"> • Maintenance and repair work should only be done by qualified personnel. • Stop the engine before doing any work on the machine. If for any reason the machine must be operated while working on it, be careful not to touch rotating parts, hot surfaces, live wires, etc. which may be unprotected. • Remove protective guards only when necessary to perform maintenance and replace them immediately after the maintenance is completed. • Use suitable tools and wear suitable clothes. • Do not modify the machine without prior authorization. 	
MOVING PARTS can injure		HOT surface can hurt you

MAINTENANCE OF THE MACHINE

Maintenance refers to all operations regarding the control and replacement of mechanical and electrical parts subject to wear. In addition it refers to the control and topping up or replacement of fluids such as fuel, oil and battery acid, and the regular cleaning of the machine.

Repairs refers to the substitution of worn or damaged parts and repairs should be carried out by Authorized Service Centers.

Refer to the Engine Manufacturer's Manual for the maintenance instructions for the engine. Periodic maintenance should be performed according to the schedule shown in this manual.

On a regular basis check that there are no obstructions in the aspiration/exhaust ducts of the alternator, the engine or the housing which could restrict the flow of cooling air.

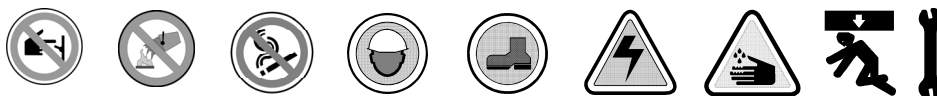

BATTERY

Check the electrolyte level in the battery periodically, especially after long periods of inactivity.

ATTENTION: the battery must have all its elements in good condition and must be filled with electrolyte.

The battery is automatically charged while the engine is running.

If the battery does not charge check the circuit breaker.

PROCEDURE FOR RECHARGING BATTERY

Remove the breather caps.

Check the electrolyte level in all compartments and, if necessary, add distilled water to the indicated level.

Replace the breather caps.

Use a densimeter to determine the charge state of the battery.

SPECIFIC WEIGHT	CHARGE PERCENTAGE
1.265	100%
1.230	75%
1.200	50%
1.170	25%

DRY AIR FILTER

Replace the air filter cartridge every 200 hours under normal conditions and every 100 hours in dusty environments.

ASYNCHRONOUS ALTERNATOR

No maintenance is necessary, as the alternator has no brushes or slip rings, and there are no devices for regulation of the output.

WARNING LABELS AND DECALS

Check warning labels and decals once a year and **replaced** if missing or unreadable.

CABLES AND CONNECTIONS

Periodically check the condition of the cables and tighten the connections.

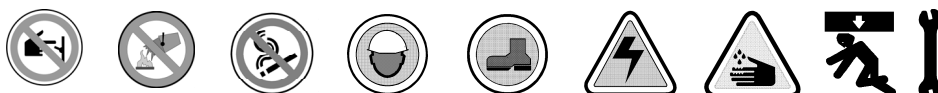

In case the machine will not be used for more than 30 days, it should be stored in a suitable area where it is protected from the elements to prevent rusting, corrosion and other damage to the machine.

DIESEL ENGINES

If the machine will be stored for short periods of time it is advisable to start the engine every 10 days and operate it for 15-30 minutes under load. This will distribute the oil, recharge the battery and prevent blockage of the injection system.

For long periods of storage, refer to the engine manufacturer's manual.

Clean the machine carefully.

Cover the machine with a plastic cover and store in a dry place.



IMPORTANT

When carrying out the operations to prepare the machine for storage, be careful to avoid polluting the environment with the materials used during maintenance. Follow all local health and safety regulations.



The KHM 190 YS is an engine driven welder and is both:

- a) a current source for arc welding b) a generator of electrical current

The machine, which is powered by an internal combustion engine, is meant for industrial and professional use.

The engine is directly coupled to a three/single phase alternator. The complete assembly is mounted inside a protective frame with lifting point using antivibration mounts.

D.C. WELDING	DC welding current/voltage at duty cycle		190A/20V at 35% 160A/26.5V at 60% 120A/25V at 100%		
	Welding current regulation (I scale) (II scale)	A	20 – 100 90 - 190		
	Open circuit voltage	V	98		
	Welding voltage	V	20 - 27		
	Electrode diameter (I scale) (II scale)	mm	2 - 3.25 2 - 4		
A.C. GENERATOR	3/1-phase, asynchronous, self-excited, self-regulated, brushless				
	Insulation	class	H		
	OUTPUT		T	M	M
			400V	230V	48V
	Duty cycle	%	100	100	100
	Power	KVA	6	5	2
	Voltage	V	400	230	48
	Current	A	8.7	21.7	41.6
	Frequency	Hz	50	50	50
Cos.	Ø	0.8	0.8	0.8	
ENGINE	Make / Model		YANMAR / L 100 AE-DEG		
	Type / Displacement / Cylinder	- / cc / no.	4 - stroke / 406 / 1		
	Power (**)	kW (CV)	6.5 (8.8)		
	Operating speed	rpm	3000		
	Cooling system		air		
	Engine oil capacity	liter	1.6		
	Starter		electric		
	Battery / acid capacity	12V / liter	60Ah / 4		
	Fuel		diesel		
GENERAL SPECIFICATION	Protection	IP	23		
	Weight (*)	kg	131		
	Dimensions Lxwxh (*)	mm	880x540x580		
	Fuel tank capacity	liter	5.5		

Note : T =three-phase M =single-phase (*) =Above values are without wheels and handles
(**)= Maximum output according to ISO 3046/1

OUTPUT - ACOUSTIC POWER LEVEL

☞ The output indicated is guaranteed at 20°C and at a pressure of 1 bar (up to 1000 m no correction for atmosphere pressure is required). At high temperature and above 1000 m altitude the engine output will decrease and the engine may need adjustment for optional performances.

☞ **N.B.:** at high altitudes, the standard mix air-fuel is excessively rich, the efficiency of the engine is reduced and, therefore, the fuel consumption will increase.

☞ Max. acoustic power level admitted according to the EEC norms of 17/09/84 n. 84/535-536.

The machine respects the noise limits, expressed in sound power, given in the a.m. directives.

These limits can be used to judge the sound level produced on site.

For example: the sound power level of 100 LWA.

The sound pressure (noise produced) at 7 meters distance is about 75dBA (the limit value less 25).

To calculate the sound level at other distances use this formula:

$$dBA_x = dBA_y + 10 \log \frac{r_y^2}{r_x^2}$$

At 4 meters the noise level becomes: 75 dBA + 10 log $\frac{7^2}{4^2} = 80$ dBA

The KHM 190 YS is an engine driven welder and is both:

- a) a current source for arc welding b) a generator of electrical current

The machine, which is powered by an internal combustion engine, is meant for industrial and professional use.

The engine is directly coupled to a three/single phase alternator. The complete assembly is mounted inside a protective frame with lifting point using antivibration mounts.

D.C. WELDING	DC welding current/voltage at duty cycle		190A/20V at 35% 160A/26.5V at 60% 120A/25V at 100%		
	Welding current regulation (I scale) (II scale)	A	20 – 100 90 - 190		
	Open circuit voltage	V	98		
	Welding voltage	V	20 - 27		
	Electrode diameter (I scale) (II scale)	mm	2 - 3.25 2 - 4		
A.C. GENERATOR	3/1-phase, asynchronous, self-excited, self-regulated, brushless				
	Insulation	class	H		
	OUTPUT		T	M	
			220V	220V	
	Duty cycle	%	100	100	
	Power	KVA	6	5	
	Voltage	V	220	220	
	Current	A	15.7	22.7	
	Frequency	Hz	60	60	
Cos.	Ø	0.8	0.8		
ENGINE	Make / Model		YANMAR / L 100 AE-DEG		
	Type / Displacement / Cylinder	- / cc / no.	4 - stroke / 406 / 1		
	Power (**)	kW (CV)	7.2 (10)		
	Operating speed	rpm	3000		
	Cooling system		air		
	Engine oil capacity	liter	1.6		
	Starter		electric		
	Battery / acid capacity	12V / liter	60Ah / 4		
	Fuel		diesel		
GENERAL SPECIFICATION	Protection	IP	23		
	Weight (*)	kg	131		
	Dimensions Lxwxh (*)	mm	880x540x580		
	Fuel tank capacity	liter	5.5		

Note : T =three-phase M =single-phase (*) =Above values are without wheels and handles
(**)= Maximum output according to ISO 3046/1

OUTPUT - ACOUSTIC POWER LEVEL

☞ The output indicated is guaranteed at 20°C and at a pressure of 1 bar (up to 1000 m no correction for atmosphere pressure is required). At high temperature and above 1000 m altitude the engine output will decrease and the engine may need adjustment for optional performances.

☞ **N.B.:** at high altitudes, the standard mix air-fuel is excessively rich, the efficiency of the engine is reduced and, therefore, the fuel consumption will increase.

☞ Max. acoustic power level admitted according to the EEC norms of 17/09/84 n. 84/535-536.

The machine respects the noise limits, expressed in sound power, given in the a.m. directives.

These limits can be used to judge the sound level produced on site.

For example: the sound power level of 100 LWA.

The sound pressure (noise produced) at 7 meters distance is about 75dBA (the limit value less 25).

To calculate the sound level at other distances use this formula:

$$dBA_x = dBA_y + 10 \log \frac{r_y^2}{r_x^2} \quad \text{At 4 meters the noise level becomes: } 75 \text{ dBA} + 10 \log \frac{7^2}{4^2} = 80 \text{ dBA}$$

Spare parts are ordered through your nearest ESAB representative, see back cover.

When ordering spare parts, please state machine type and number as well as designation and spare part number, according to the spare parts list.

This will simplify dispatch and ensure you get the right part.

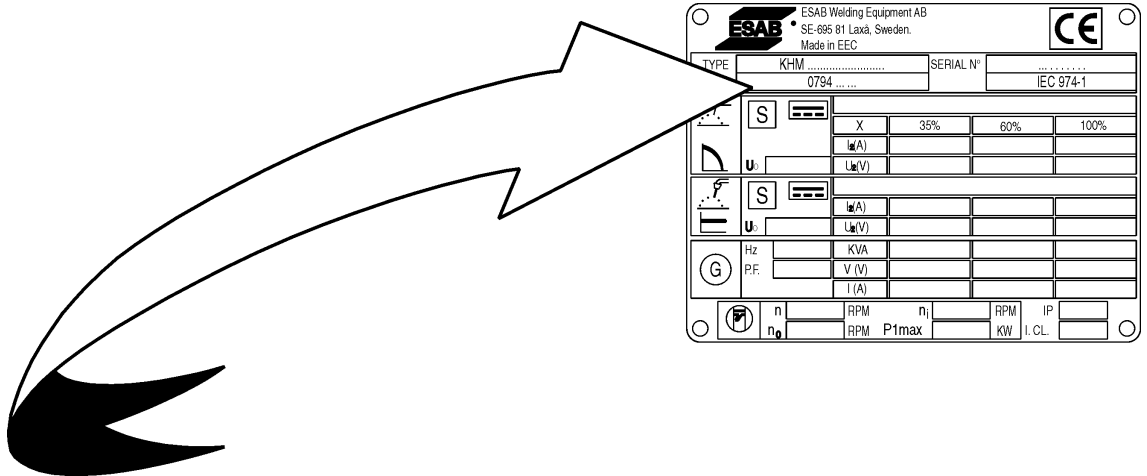

When ordering the spare parts, it is recommended to indicate:

- 1) * serial number
- 2) * model of welder and/or generating set
- 3) ◆ part number
- 5) quantity

* The requested data are to be found on the rating plate of the machine.